



# AMERICAN SERIES CROSSOVER POST



## RECOMMENDED TOOLS

- Safety Glasses
- Tape Measure & Pencil
- Power Drill
- Socket Wrench
- Level
- Saw with Finetooth Blade
- Bolt Cutters

## AMERICAN SERIES CROSSOVER POST KIT COMPONENTS ←

- 2.5" Post with Post Cap
- Crossover Sleeve
- Pedestal
- Sleeve Cover
- (5x) #10 Flat Head Screws

- **These directions are only a guide** and may not address every situation.
- Always wear proper safety equipment while assembling and installing.
- The installer should obtain all required building permits and follow all installation procedures in accordance with applicable building code requirements.
- Superior Outdoor Products, Inc. shall not be held liable for improper or unsafe installations.
- Applying paint, other than Keylink's touch up paint, will void your warranty.
- To ensure proper coverage by our warranty please visit our website and complete the online warranty registration form or mail a copy to: Keylink, 110 Peters Road, New Holland, PA 17557



WARNING: This product can expose you to chemicals including Quartz (crystalline silica), which is known to the State of California to cause cancer, and Hexavalent Chromium, which is known to the State of California to cause birth defects or other reproductive harm. For more information go to [www.P65Warnings.ca.gov](http://www.P65Warnings.ca.gov).



# AMERICAN SERIES CROSSOVER POST PREPWORK

This guide will provide information on the Crossover Post, Crossover Corner Post and the Horizontal Cable Variation. Below is an exploded diagram of all components included:

## CROSSOVER POST (Excluding Horizontal Cable)

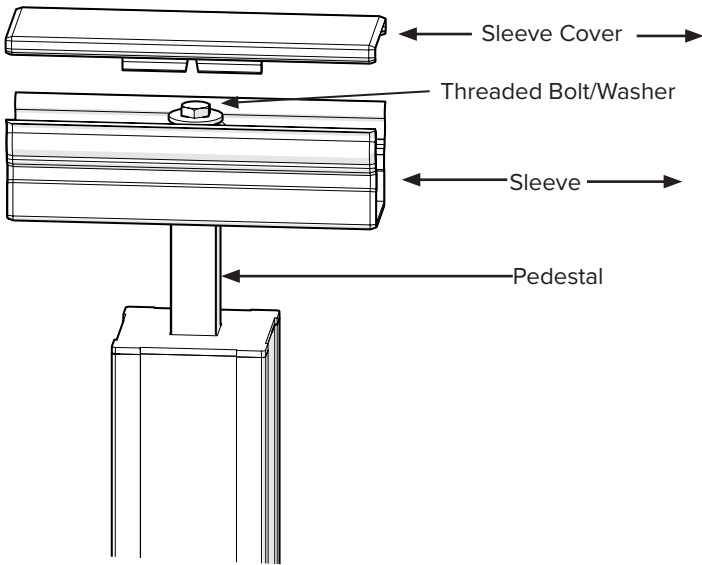

## CROSSOVER POST (Horizontal Cable)

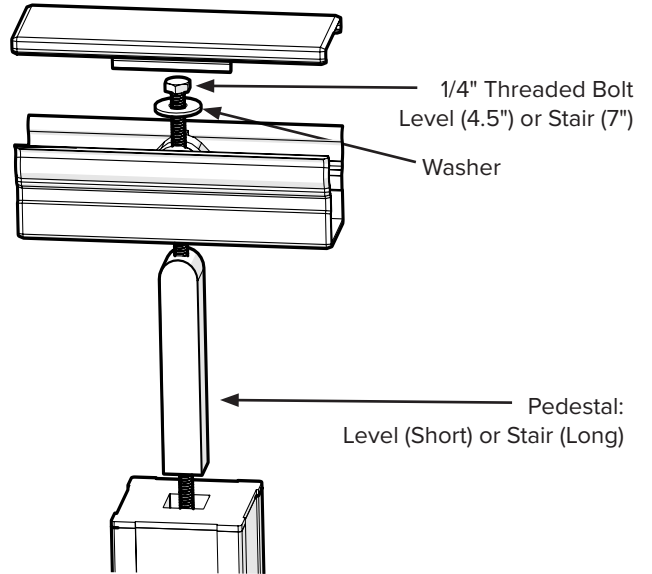

## CROSSOVER CORNER POST

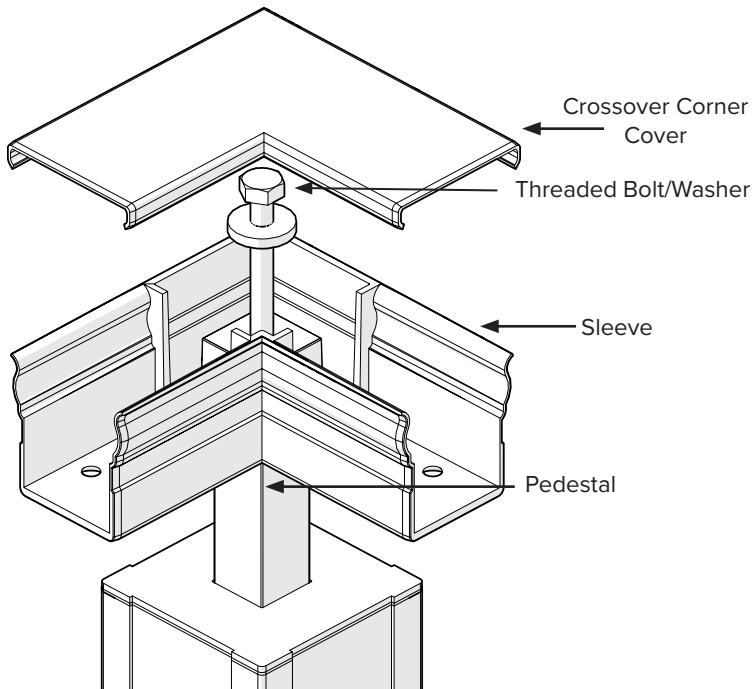

## 1

**STEP ONE: INSTALL POST**

Space posts according to \*application and top rail length. Place the leveling plate between post and mounting surface.

Attach to structural surface using bolts or lags (not included). Partially tighten prior to leveling. Using a 3/16" Allen wrench, turn set screws to level post. Then fully tighten structural screws.

After post is installed, put on the post ring trim cover.

\*Check your local building codes to determine structural mounting requirements for Post.

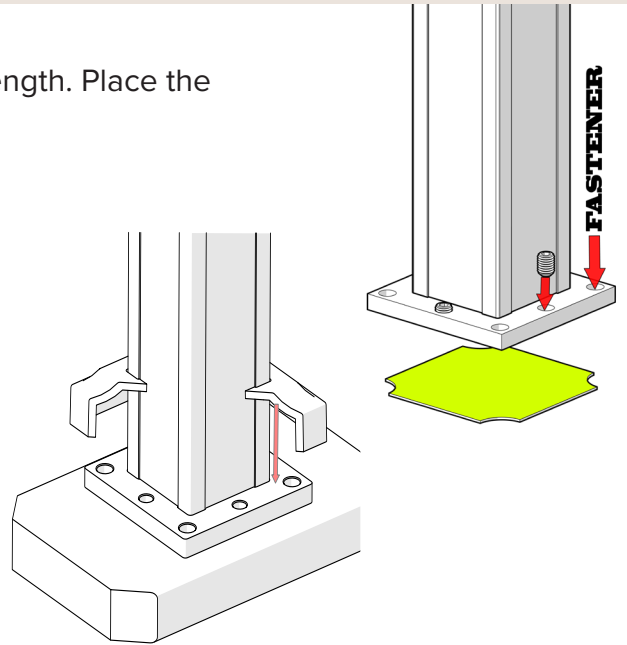

## 2A

**SLEEVE POSITIONING**

By turning the bolt with a wrench or socket, set the desired height.

Distance of travel from bottom of Sleeve to top of Post Cap:

- 4" Height: highest travel distance
- 1.5" Height: lowest travel distance

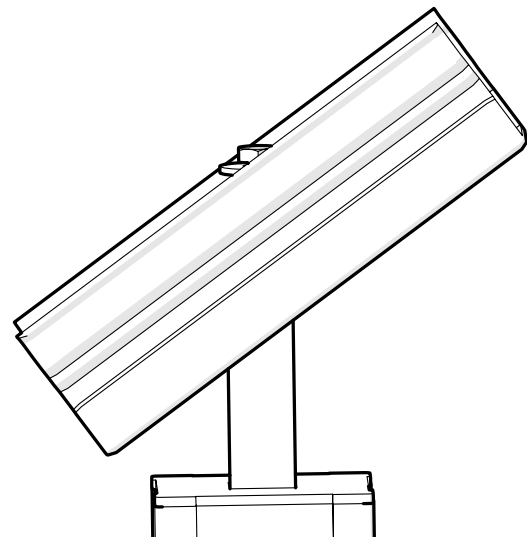
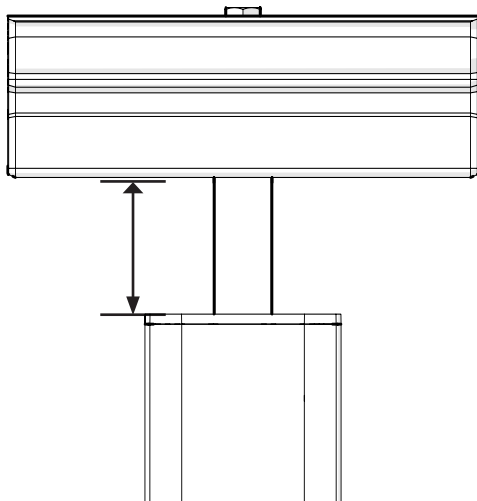

If using for a stair application, make sure to tilt Crossover Sleeve assembly to desired angle.

## ! TROUBLESHOOTING TIP:

In the event that the pedestal doesn't raise as expected when turning the bolt, simply remove the bolt entirely and finger tighten the two nuts against the bottom of the pedestal. Using two wrenches turn the 'jam nuts' in opposite directions while tightening them to each other. Simply reinsert the pedestal via the bolt and resume normal operation.

**NOTE:** This does not apply to Horizontal Cable Posts.

## 2B HORIZONTAL CABLE SLEEVE POSITIONING

Make sure to adjust the Crossover Sleeve to desired angle. Use a socket/wrench to tighten the Threaded Bolt with the Post Cap.

**NOTE:** If adjustment is needed to match the rail height on a stair section, use the longer pedestal and bolt. These can be cut to the necessary length to match the height of the sleeve with the height of the rail.

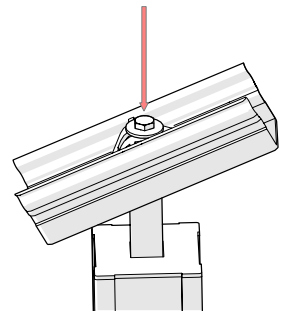

## ! HORIZONTAL CABLE RAIL HEIGHT

Using a Horizontal Cable Crossover Post requires rail height to be 36.5" or 42.5"

## ! CUTTING TIP

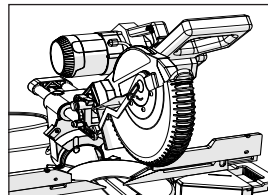

Be sure to use a fine-tooth blade approved for cutting aluminum and rest rails on a piece of non-abrasive material to protect from scratches.

## 3 JOIN TOP RAILS TO SLEEVE

After the Crossover Post is installed and Sleeve assembly is in place, click in the top rail into the Sleeve as shown, and mark rails for predrill holes.

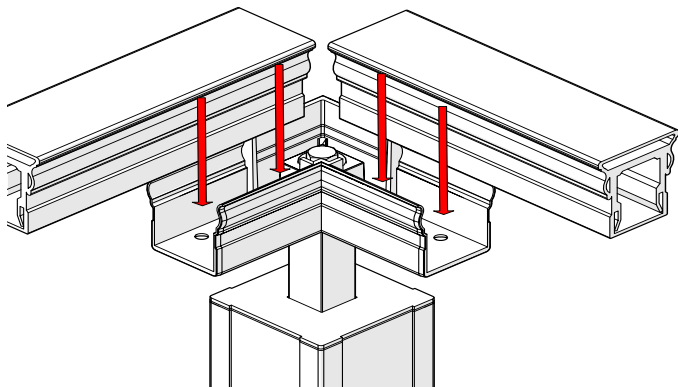
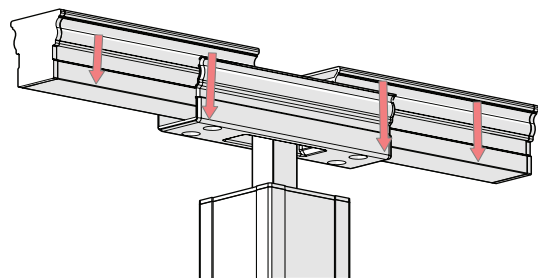

## ! OPTIONAL STEP

If using a Crossover End Cap, install on terminating post in place of top rail.

## 4

**FASTEN TOP RAILS TO SLEEVE**

Pre-drill (4) holes as indicated, then drive the four #10 screws (included) from the bottom of the Sleeve to attach each side to the top rail.

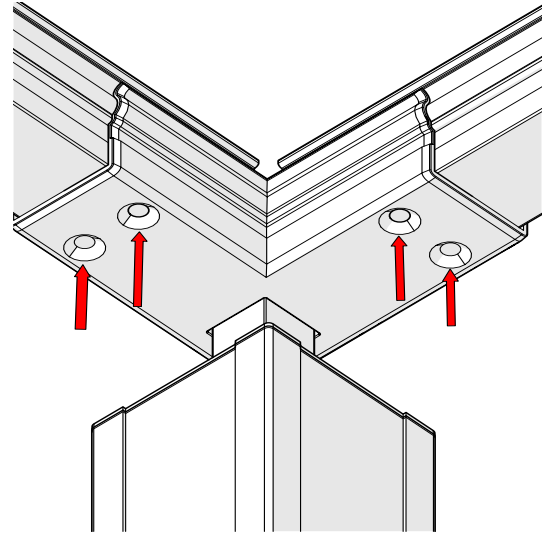
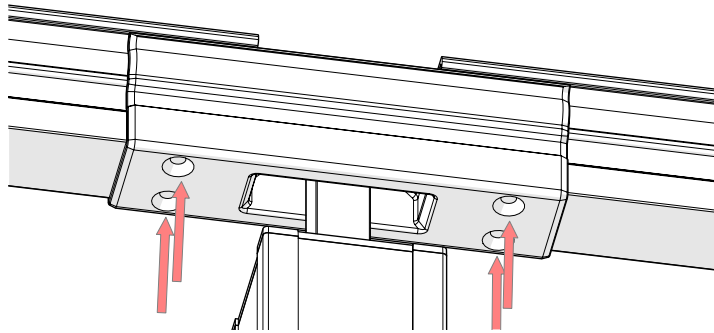

## !

**STAIR SECTION TIPS:**

- When installing multiple rail sections, make sure to start at the bottom of the stair run and work up.
- Assembling each section prior to installing it onto the Crossover Post greatly simplifies installation
- Fasten the rail to the post at the top of the section first (Step 1), preattach any brackets, and then rack the section by rotating down to meet with the post at the bottom of the section (Step 2).

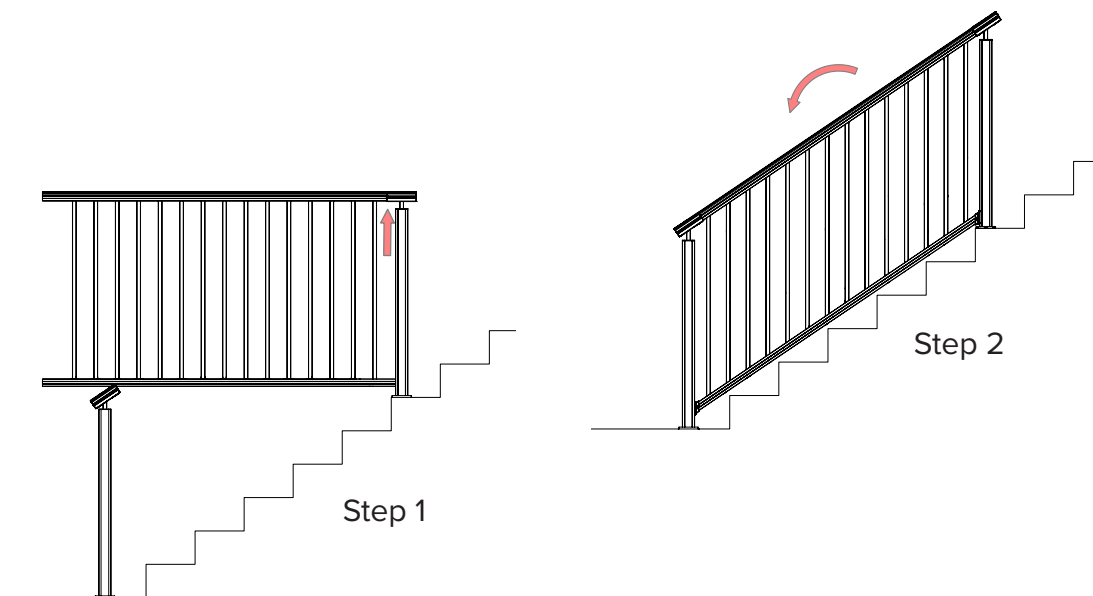

## 5

## SNAP THE SLEEVE COVER ONTO THE RAILS

Once the top rails are joined, apply the Sleeve Cover onto one side of the Sleeve (1), making sure to center the slit in the Cover with the rib on the Sleeve.

Lastly, pivot the Cover along edge (1) and snap onto edge (2) to secure.

For the Crossover Corner Cover, snap in on side **A**, then side **B**.

