

ALUMINUM RAILING

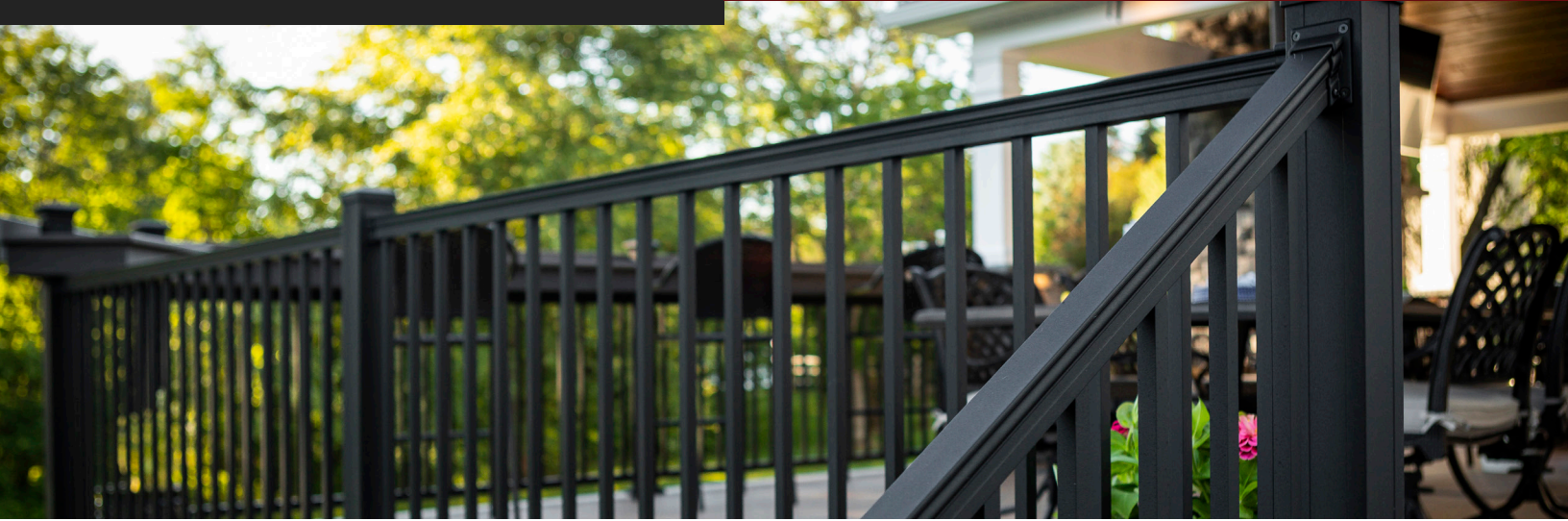

INSTALLATION GUIDE



WHAT'S INCLUDED

- Top and Bottom Rails
- Balusters
- Mounting Brackets
- Snap on Support (for 8' sections)
- (17) #12 Flat Head Screws
- (9) #10 Pan Head Screws

RECOMMENDED TOOLS

- Safety Glasses
- Tape Measure & Pencil
- Saw w/ fine-tooth blade
- Rubber Mallet
- Level
- Power Drill w/ square bit driver
- Hammer Drill (if concrete install)

1. These directions are only a guide and may not address every situation.
2. Always wear proper safety equipment while assembling and installing.
3. The installer should obtain all required building permits and follow all installation procedures in accordance with applicable building code requirements.
4. Keylink Fencing and Railing Inc. shall not be held liable for improper or unsafe installations.
5. Applying paint, other than Keylink's touch up paint, will void your warranty.
6. To ensure proper coverage by our warranty please visit our website and complete the warranty form and mail to: Keylink, 110 Peters Road, New Holland, PA 17557

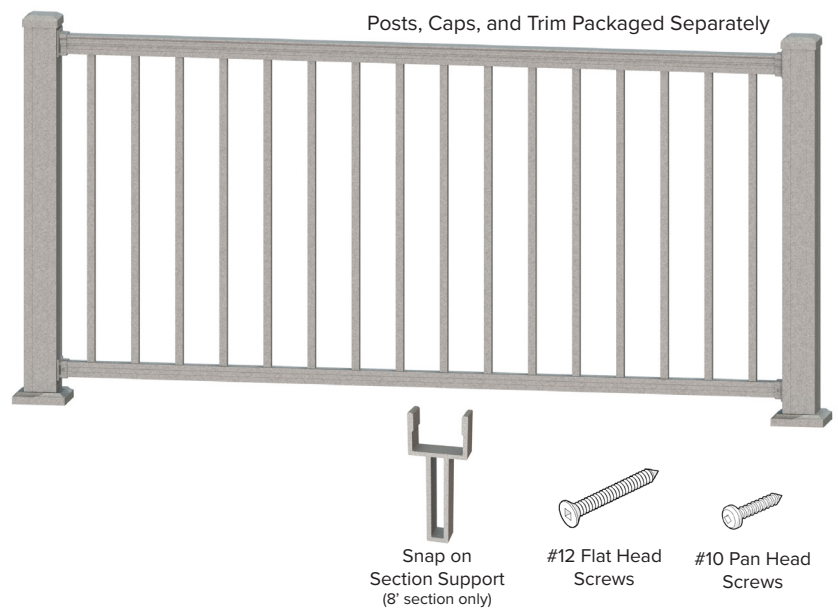

WARNING: This product can expose you to chemicals including Quartz (crystalline silica), which is known to the State of California to cause cancer, and Hexavalent Chromium, which is known to the State of California to cause birth defects or other reproductive harm. For more information go to www.P65Warnings.ca.gov.

1 INSTALL THE POSTS & POST TRIM

Space Posts according to *application and Top Rail length. Place leveling plate (highlighted) between Post and mounting surface.

Attach to structural surface using bolts or lags (not included). Partially Tighten prior to levelling. Using 3/16" Allen wrench, turn set screws to level Post. Then fully tighten structural screws.

■ *Check your local building codes to determine structural mounting requirements for post.

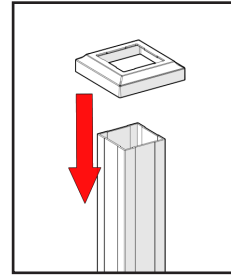

Placing trim

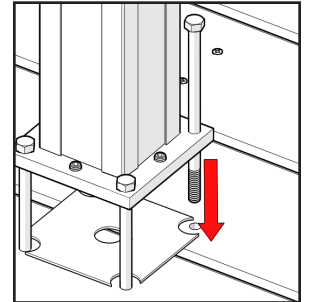

2 ATTACH BOTTOM RAIL

Measure between posts subtracting 1/4" from total length, and if necessary cut Rail to proper length by cutting an equal amount from each end. Do not cut through Baluster holes

Slide the bracket over the rail, then put the rail in place (2 1/2" above deck surface) and slide the self-centering bracket against the post. Fasten bracket to post using #12 screws, and secure bracket to railing using #10 pan-head screws.

TIP: Cut a block to 2 1/2" and set Bottom Rail on it for support during installation. *Recommended: (If using 2-1/2" corner Posts) offset inside edge screws with alternating angles to help avoid Mounting Bracket screw interference.

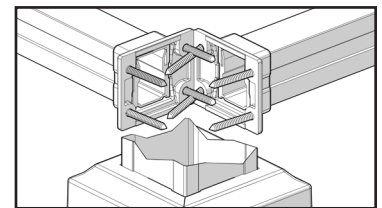
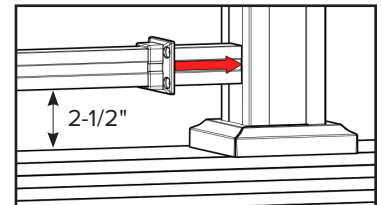
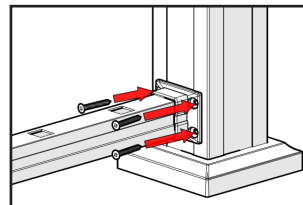

*2-1/2" Post: screw offset shown

3 INSTALL BALUSTERS

Insert balusters into the holes in the bottom rail. Push firmly to set.

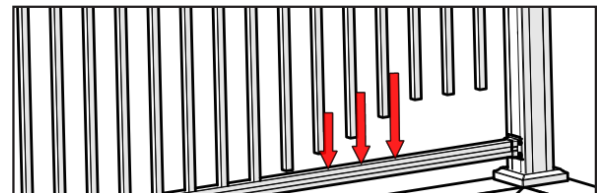

4 ATTACH TOP RAIL & MIDDLE RAIL (IF APPLICABLE)

Place Top Rail 36" or 42" from the deck surface to the top face of the Rail, and onto balusters. Fasten to post using self-centering brackets and #12 screws. Ensure that balusters are properly seated in railing before securing bracket to railing using #10 pan-head screws. Repeat for Middle Rail.

Place cap on post and use rubber mallet to set in place.

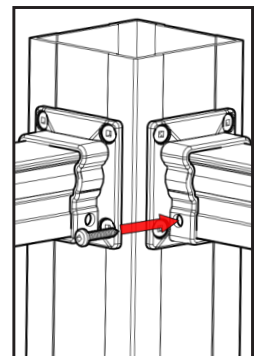
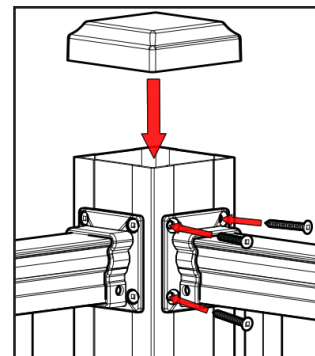

5 INSTALL STAIR RAILING

Measure from inside edge between posts subtracting 1/4" from total length, and if necessary cut Rail to proper length by cutting an equal amount from each end. Do not cut through Baluster holes

To ensure rails align properly. Cut Upper and Lower ends of Top and Bottom Rails at opposite angles.

(Standard stair angle is 34°)

Repeat steps 2 through 4 to Install Rails, Mounts, and balusters.

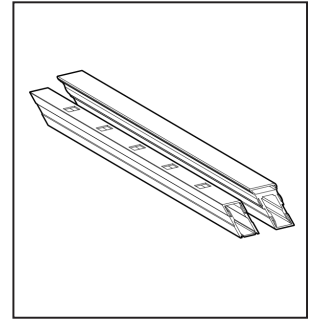
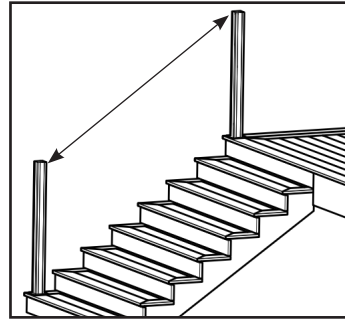

! Verification: For stair sections, mount as shown below:

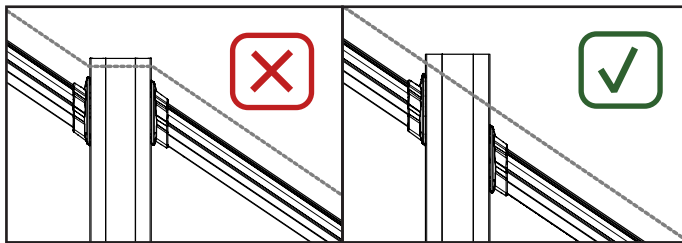

Ensure that the stairs' Top Rail doesn't exceed the level rail height of the opposite Rail.

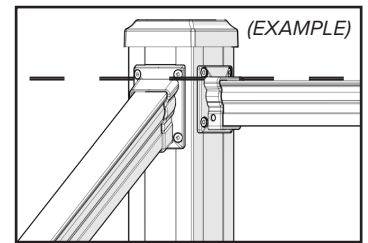

! CUTTING TIP

Be sure to use a fine-tooth blade approved for cutting aluminum and rest rails on a piece of non-abrasive material to protect from scratches.

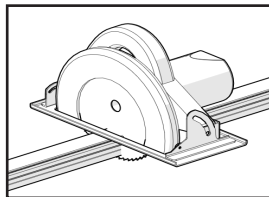

■ NOTE: Always check local building codes to ensure compliance as there are mandates regarding the size opening beneath the bottom rail.

CHESAPEAKE SERIES RAIL OPTION

WHAT'S INCLUDED

- Top and Bottom Rails
- Balusters
- (2) Deckboard Mounting Brackets
- (2) Bottom Level Brackets
- Snap on Support (for 8' sections)
- (17) #12 x 1" Self Drilling Flat Head Screws
- (9) #10 x 3/4" Self Drilling Pan Head Screws
- (15) or (19) #8 x 3/4" Type 17 Pan Head Screws

1 CUT POSTS TO HEIGHT (OPTIONAL)

Posts are provided at a standard height, and must be cut to length (Prior to section's installation).

Refer to step 5 for Top Rail height, and cut Posts to match overall height.

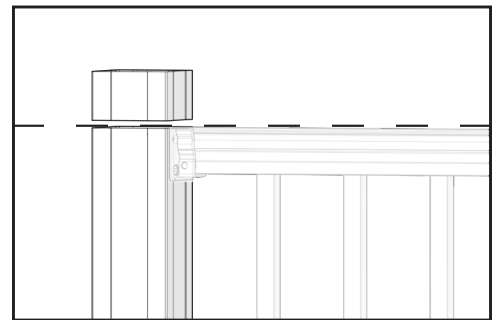

2 INSTALL DECKBOARD (OPTIONAL)

Using the supplied #8 x 3/4" pan head screws fasten the deckboard (not supplied) to the top rail from beneath by using the predrilled holes of the top rail. It is recommended to drill a 1/8" pilot hole in the deckboard to avoid splitting.

! Drilling Pilot Holes

If the rail has been cut to another length, drill 3/16" pilot holes evenly spaced in the aluminum top rail channel. Pilot hole must be at least 2" from end of rail.

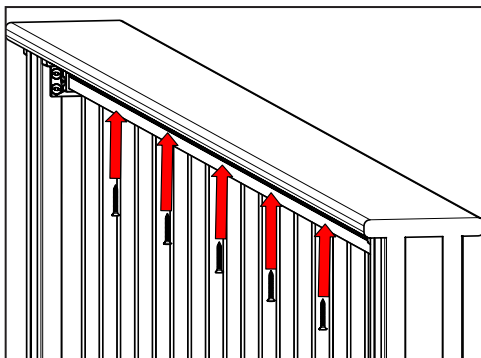

! Corner Install Recommendation

When installing the corner of a railing it is recommended to insert a wood block in the top of the post. Cut the block to fit snugly in the post. When fastening the top brackets with the provided #12 x 1" screws the screws should also secure the wood block. Using wood screws (not provided), secure the deck board to the wooden block. This will ensure the edges of the deckboard do not lift up.

